

Static Lean Table:

Static Lean

S

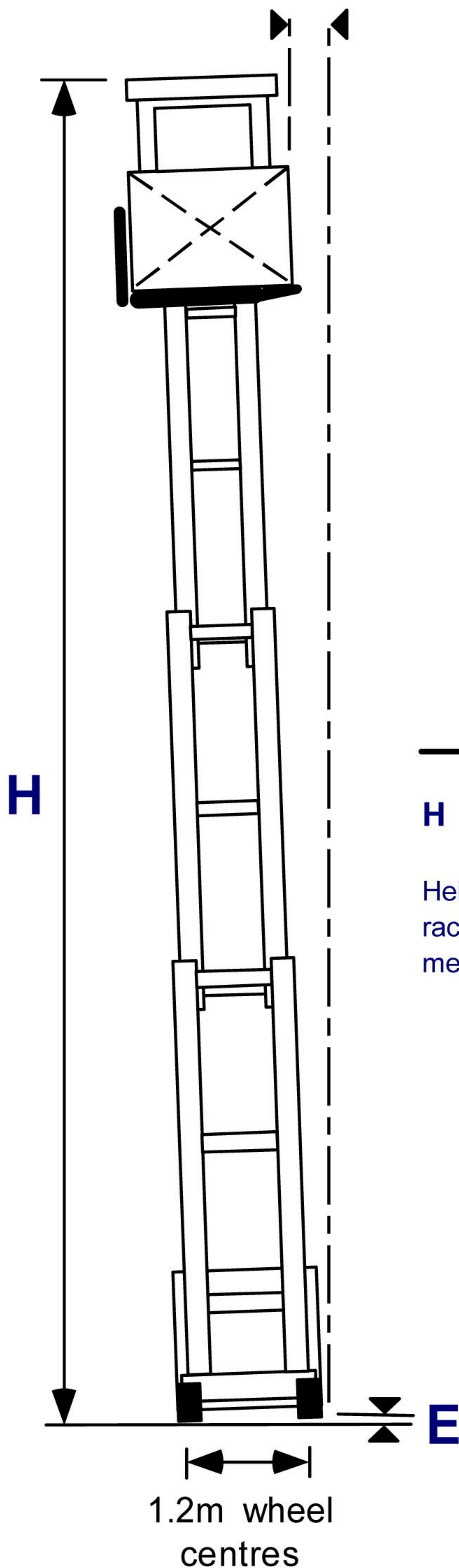

This table shows the relationship between the static lean of a forklift truck, due to the difference in elevation between the left and right hand forklift truck load wheels, and the height of the racking, assuming that the mast is a rigid structure.

However, due to the mechanical tolerances in the mast, and the dynamic considerations when the truck is moving with a load at a height, the lean could **increase up to three times** the figure shown.

This particular set of figures is based on a typical wheel spacing of 1200mm, from centre to centre of the outer load wheels.

		E (mm) = The difference in elevation between left and right hand VNA truck wheels									
		3	4	5	6	7	8	9	10	11	12
H = Height of racking in metres	6	15	20	25	30	35	40	45	50	55	60
	6.5	16	22	27	33	38	43	49	54	60	65
	7	18	23	29	35	41	47	53	58	64	70
	7.5	19	25	31	38	44	50	56	63	69	75
	8	20	27	33	40	47	53	60	67	73	80
	8.5	21	28	35	43	50	57	64	71	78	85
	9	23	30	38	45	53	60	68	75	83	90
	9.5	24	32	40	48	55	63	71	79	87	95
	10	25	33	42	50	58	67	75	83	92	100
	10.5	26	35	44	53	61	70	79	88	96	105
	11	28	37	46	55	64	73	83	92	101	110
	11.5	29	38	48	58	67	77	86	96	105	115
	12	30	40	50	60	70	80	90	100	110	120
	12.5	31	42	52	63	73	83	94	104	115	125
13	33	43	54	65	76	87	98	108	119	130	